

**NEW**

**PIUSI**

**HIGH PERFORMANCE**

**HIGH PRESSURE**

**CONTINUOUS DUTY**

**56  
l/min**

**56  
l/min**

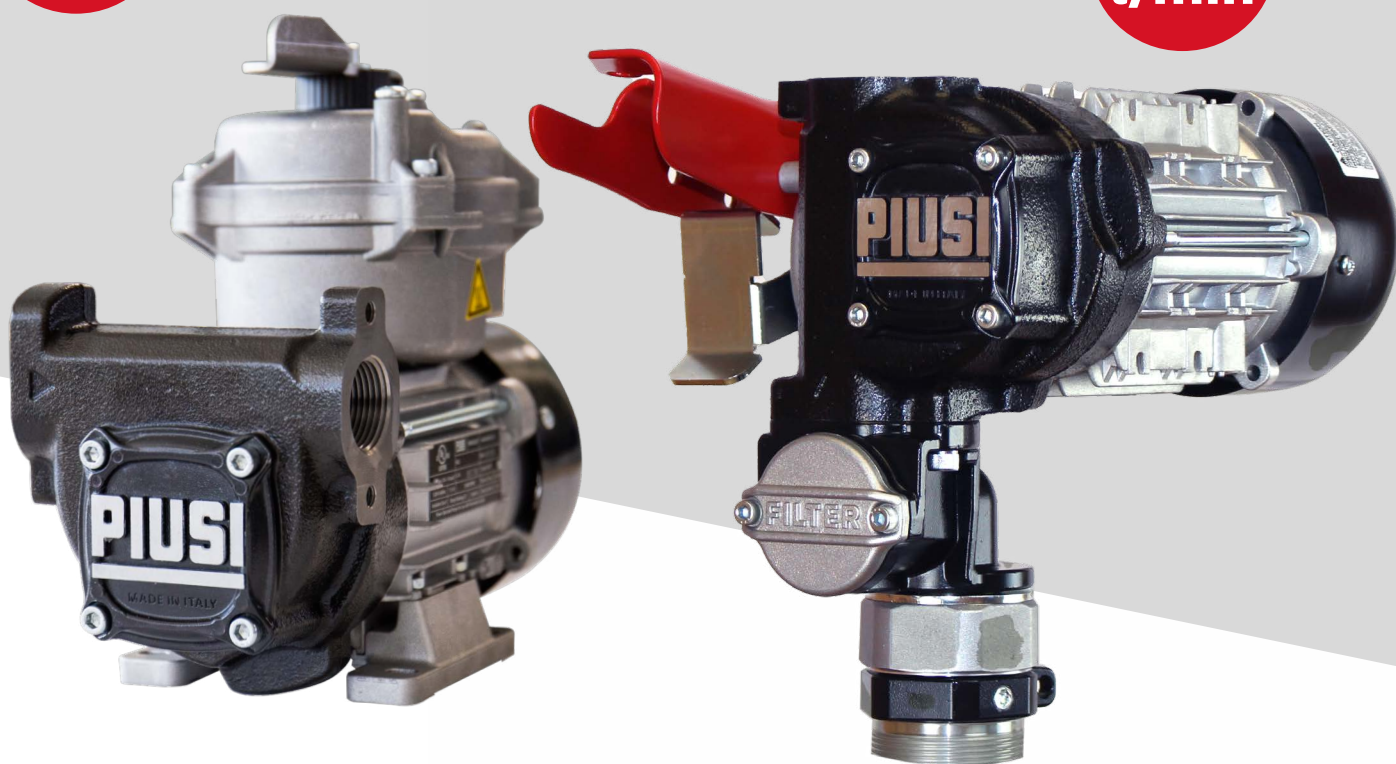

# **PANTHER EX SERIES**

**NEVER-BEFORE-SEEN  
PERFORMANCE IN REFUELING!**

# MAIN ADVANTAGES WITH PANTHER EX SERIES



The new PIUSI-branded **PANTHER EX AC** pump series is designed to satisfy the most demanding customers who need robust and reliable pumps that provide unique performance.

Years of research and study of diverse fueling applications have enabled PIUSI to develop this innovative pump. Capable of providing the highest flow rate of its class,

it outperforms even while using a range of accessories. The PANTHER EX **is available in 56 l/min**. This pump is designed to deliver their true flow at the nozzle at high pressures, allowing them to be used on an array of tank sizes and configurations.

## ADVANTAGES:

1

**Sturdiness:** built to perform, PANTHER EX are made with high-quality materials and a durable construction that works in the harshest conditions. All seals are made of special Viton for extreme temperatures and ensure high reliability in both diesel and gasoline transfer down to (-30°C).

2

**Unrivaled Flow-rate:** with incredible flow rates, PANTHER EX offer the highest performance in the market. The ability to deliver fuel efficiently and quickly makes it ideal for refueling vehicles of any size ensuring a steady flow even on complex systems.

3

**Ease of use:** PANTHER EX pumps are designed to be intuitive and easy to use. Refueling operations become a simple task; even in challenging environments.

4

**New tank Connection:** designed to ensure a quick and easy installation, the new **2”BSP** bung adaptor allows the pump to be mounted smoothly and securely fastened with its Easy Lock union ring. The new Easy Lock system adds security to your system, as well, by allowing the pump to be anchored to the tank using a padlock.

5

**Long-lasting durability:** with an innovative design and high-quality materials, this pump is built to last. Able to work in **CONTINUOUS DUTY S1**, it avoids unnecessary downtime when refueling large fleets. Its reliability is an investment in the future of your business.

6

**Safety first:** Safety is our top priority. The motor is designed to ensure continuous service under all conditions. The new contactless switch is maintenance-free.





**(EX) PANTHER EX 56 230V 50HZ FEET -PUMP ONLY-**



**(EX) PANTHER EX 56 230V 50HZ DRUM -PUMP ONLY-**

Maintaining a reliable and efficient fueling process is critical. Don't settle when it comes to refueling your business, the new PANTHER EX represents the height of innovation and reliability in the industry. Choose the quality, sturdiness and superior performance that only PANTHER EX can provide.

**Step forward and discover the difference it can make to your business!**

## EX50 VS PANTHER EX AC: DIMENSIONS COMPARED

**EX 50**



**PANTHER EX**

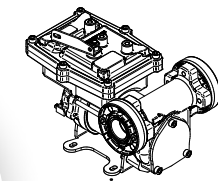
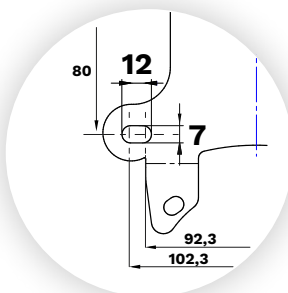
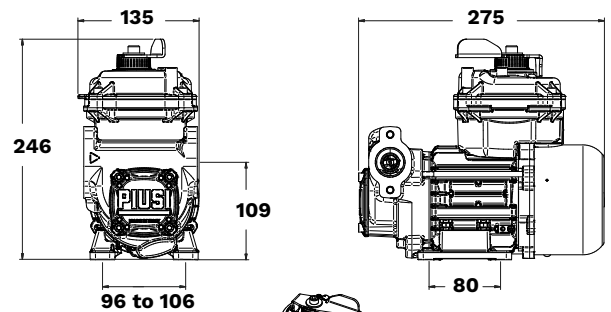
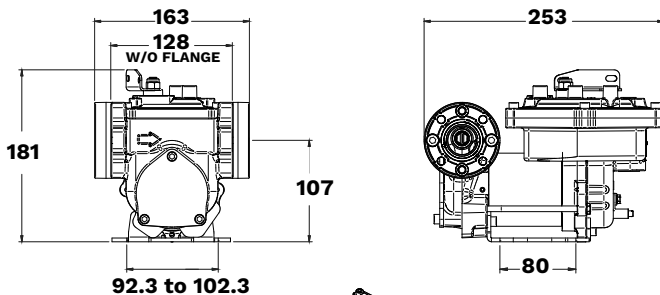

**Fixing feet eyelet**

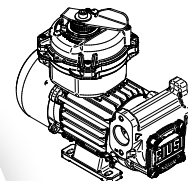
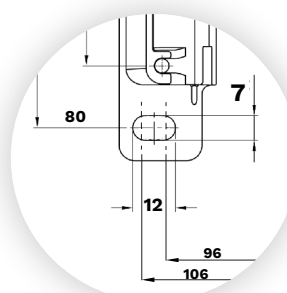

**Fixing feet eyelet**

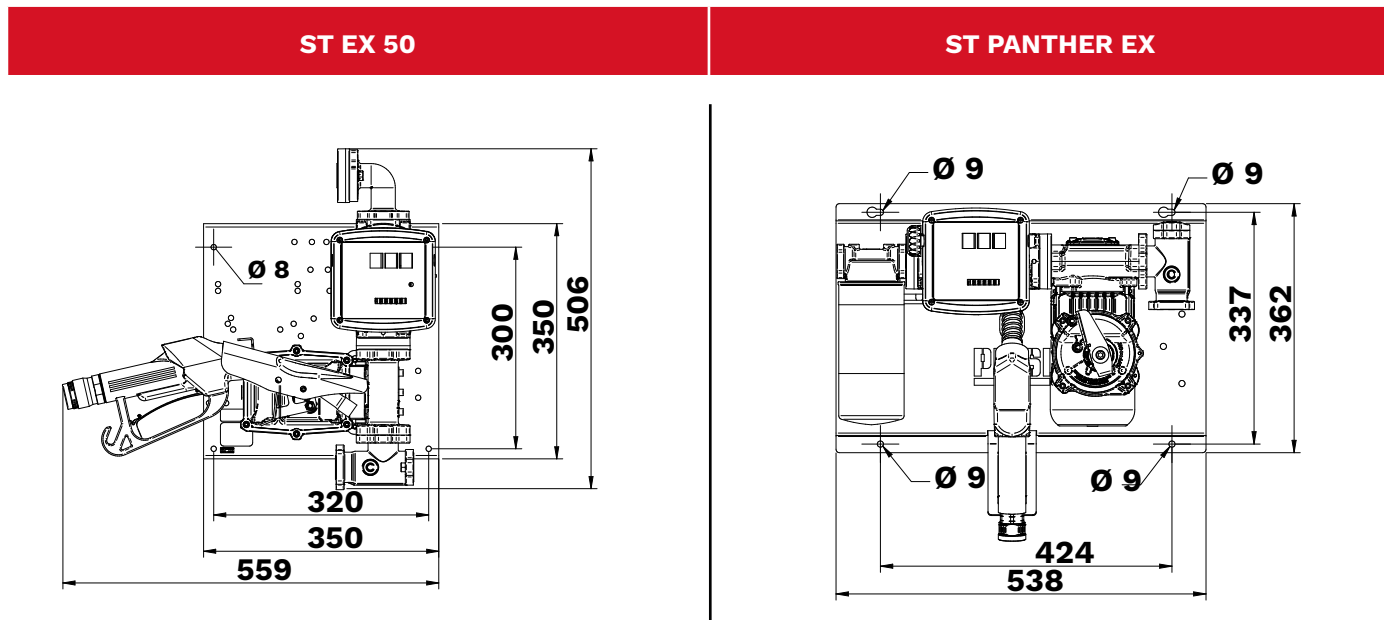

Code	Description	Flow-rate l/min	Voltage / frequency	Max. Pressure bar	Continuous Duty	Meter	Nozzle	Filter
<b>F00580000</b> Available from November	(Ex) Panther EX 56 230V 50Hz Feet -Pump Only-	56 l/min	230V 50Hz	1,8	S1	-	-	-
<b>F00580010</b> Available from November	(Ex) Panther EX 56 230V 50Hz Drum -Pump Only-	56 l/min	230V 50Hz	1,8	S1	-	-	-
<b>F00582000</b> Available from December	(Ex) DRUM Panther EX 56 230V 50Hz 4m Auto Nozzle + water captor filter (Atex)	56 l/min	230V 50Hz	1,8	S1	-	A60	Water captor Atex
<b>F00582010</b> Available from December	(Ex) DRUM Panther EX 56 230V 50Hz K33 4m Auto Nozzle + water captor filter (Atex)	56 l/min	230V 50Hz	1,8	S1	K33	A60	Water captor Atex
<b>F00584000</b> Available from December	(Ex) ST Panther EX 56 230V 50Hz K33 4m Auto Nozzle + water captor filter (Atex)	56 l/min	230V 50Hz	1,8	S1	K33	A60	Water captor Atex

**Fluids type:**

The pump can only be used with the specified fluids: Diesel, Gasoline, Kerosene, Gasoline mixed with alcohol Max. 15%, Aspen 2/4, Paraffinic HVO/XTL: EN15940

Always refer to the instruction manual before any use.



**piusi.com**

PIUSI S.p.A. • 46029 Suzzara (Mantova)  
tel. +39 0376 534561 • [piusi@piusi.com](mailto:piusi@piusi.com)